



# Viper<sup>®</sup>-ST

Solid Dielectric, Independent Pole Operated Recloser

Providing electronic overcurrent protection for single or three-phase operation

**G&W** Electric  
Engineered to order. Built to last.

# Leader in Recloser Technology

As the leading supplier of reclosers in North America, G&W Electric offers the latest technology backed by more than 115 years of experience, training, and support. Our Viper recloser line for the medium voltage market is chosen by utilities all over North America for its superior performance in any environment.

The Viper-ST recloser provides reliable, maintenance-free performance for overcurrent protection with flexibility to isolate faults on single-phase, two-phase, or on three-phase circuits, further improving grid reliability.

## Viper®-ST Overview

Viper-ST is a pole mounted recloser that combines the time proven reliability of electronically controlled, vacuum fault interrupters with the maintenance-free benefits of a solid dielectric insulated device. The recloser offers user flexibility by permitting three distinct mechanical operating modes.

- 1-phase trip / 1-phase lockout
- 1-phase trip / 3-phase lockout
- 3-phase trip / 3-phase lockout

The Viper-ST recloser provides overcurrent protection for medium-voltage systems through 38kV, 800A continuous current, and 12.5kA symmetrical interrupting ratings with options for 16kA up to 27kV.

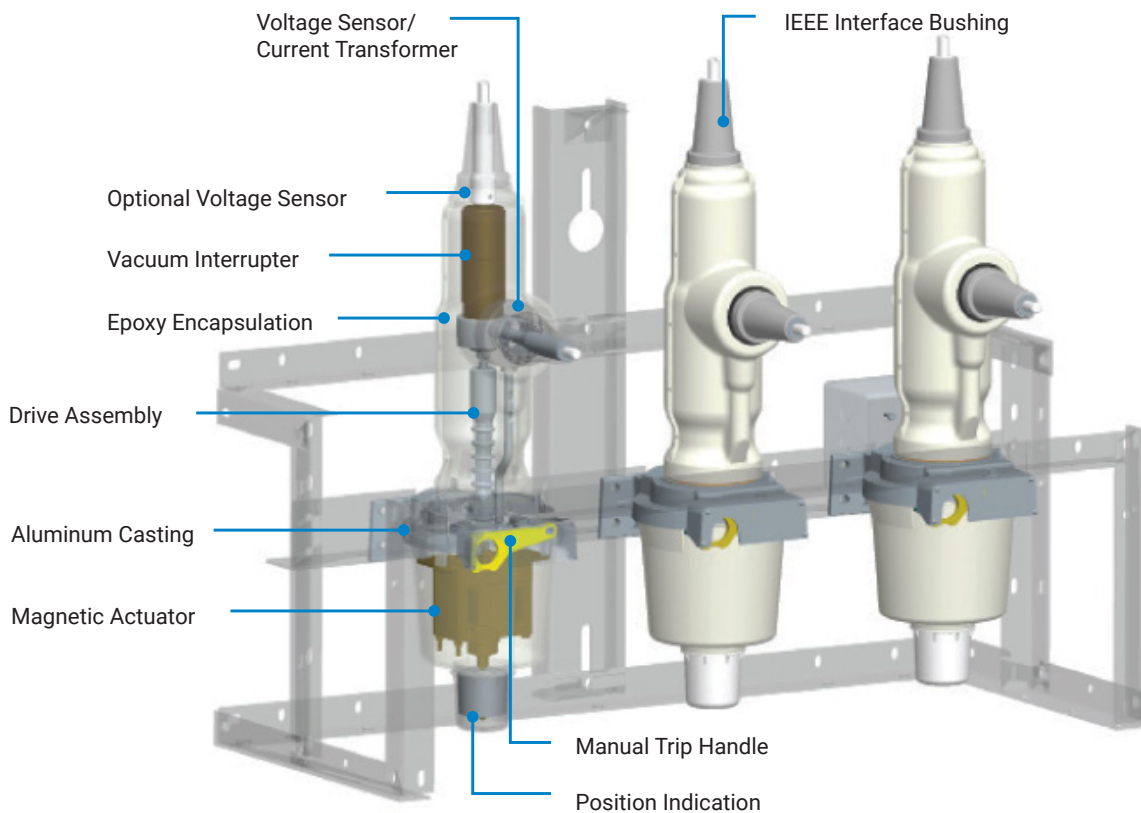

*Isometric view of the Viper-ST without insulators.*

## BENEFITS

### Reliable Performance

- Utilizes time-proven epoxy to fully encapsulate the vacuum interrupter
- Offers excellent insulation while providing fully shielded construction
- All modules are UV protected and 100% factory tested for partial discharge
- Utilizes the latest in magnetic actuator technology
- Interrupter and actuator assembly tested for over 10,000 mechanical operations to ensure a long operating life

### Operator Safety

- Vacuum interrupter and all energized parts are sealed within solid dielectric insulation
- Installation flexibility with “L”-shaped and “Z”-shaped module designs
- Module bodies are fully grounded to provide a dead-tank construction, providing optimum operator safety and additional protection to wildlife
- Hot stick operable, manual trip and lockout handle prohibits operation from either the control or remotely
- Manual trip handle with true mechanical blocking device further ensures against accidental close
- Open and closed contact indicator verifies contact position
- Contact status and lockout condition can also be verified at the control

### Application Flexibility

G&W Electric provides a consultative approach to your recloser design. Our engineers will provide you a design that meets your specific needs. Customized control cabinets, recloser frames and category 4 hurricane proof designs are some of the options available to our customers.

- Units are designed for overhead, substation and padmount applications
- Pole mounted units can be equipped with either one horizontal and vertical insulator or both horizontal insulators
- Designed with IEEE 386 interface apparatus bushings permitting the use of either long lasting silicone insulators for overhead applications or elbow connectors for padmount or riser applications
- Removable silicone insulators are standard for overhead applications, providing easy field replacement if an insulator is damaged
- Higher external BIL rated insulators can also be used in high pollution areas and can be retrofitted on-site if necessary

### Maintenance Free

- Solid dielectric insulation provides maintenance-free installation
- Electronic equipment associated with the operation of the magnetic actuator(s) are located in the control

### Ease of Operation

- Compatible with the SEL-651R, Beckwith M-7679, ABB RER620, and GE R650 controls with 32-pin and 42-pin interfaces
- Site-ready options including cable connections available

*38kV Viper-ST recloser with center mount frame.*



## Viper-ST Operation Principle

The Viper-ST recloser monitors the circuit using internal dual-ratio current transformers and current transformers (CT) and voltage voltage sensors. The unit is powered by an external 120 VAC or 48/125 VDC source with energy to operate the mechanism coming directly from the control, so no electronics are required in the recloser mechanism.

### Solid Dielectric Modules

The Viper-ST modules are manufactured with an IEEE 386 apparatus bushing interface. Removable silicone insulators are standard for all overhead applications. If higher external BIL ratings are required due to high altitude or local environmental conditions, higher rated insulators can be provided initially or retrofitted in the field by personnel. For dead-front, padmounted applications, 600A apparatus bushings or 200A deep well bushings (up to 27kV) are available.

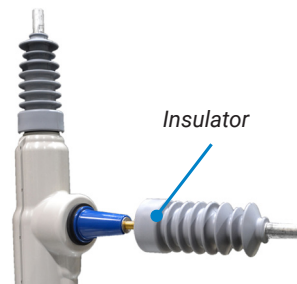

Silicone insulators are removable permitting easy replacement in the field if damaged or if higher external BIL level is required.

### Integrated Current and Voltage

- A 1000/500 dual ratio current transformer is encapsulated within each module. An optional 400/200:1 dual ratio CT is also available for lower current detection.
- CT accuracy is +/-1%.
- Capacitive voltage sensors are encapsulated within each module and operate at Low Energy Analog (LEA) levels. The accuracy +/-2% over the temperature range -20°C (-4°F) through +40°C (104°F) and +/-4% from -60°C (-76°F) through +65°C (149°F). The voltage sensing phase angle accuracy is +/-1° throughout the full temperature range.

### Accusense Voltage Sensors

Accusense Voltage Sensors are a metering-class voltage sensing solution that enables users to collect critical voltage data needed for optimizing grid power delivery and reliability. Accusense voltage sensing technology eliminates the need for metering with traditional voltage transformers and is available as a site-ready solution with the Viper-ST.

Accusense voltage sensors have been tested to IEC 60044-7:1999 standard and comply with 0.5 accuracy class ( $\pm 0.5\%$  Magnitude,  $\pm 0.344^\circ$  Phase). They are rated to operate up to 38kV voltages, 225kV BIL, -40°C to +65°C temperature range, and do not require ratio correction factors.

### Manual Trip Operation

- The hookstick manual trip handle trips and locks out the selected phase, disabling any local or remote closing operation until the handle is reset
- Once reset, the recloser can be closed using the control
- Contact position indicator displays open or closed status of the contacts for each phase, module contact status is also displayed at the control
- Handle is operable from ground level

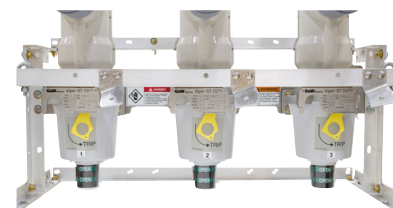

Open position

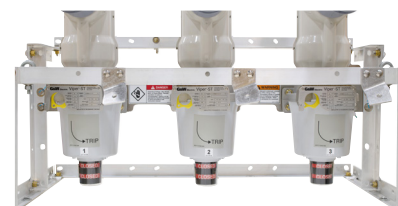

Closed position

### Dead-Line Operation

- Unique design of magnetic actuator system provides for local and remote operation if the AC source power is lost or interrupted
- Dead-line operation allows the unit to operate through the battery located in the control

# Viper®-ST Recloser Configurations

## Polemount Center Bracket (15kV shown)\*

- Centermount frames are available in aluminum as standard
- Frames can be designed to incorporate site-ready accessories, such as potential transformers and lightning arresters



15kV center polemount Viper-ST

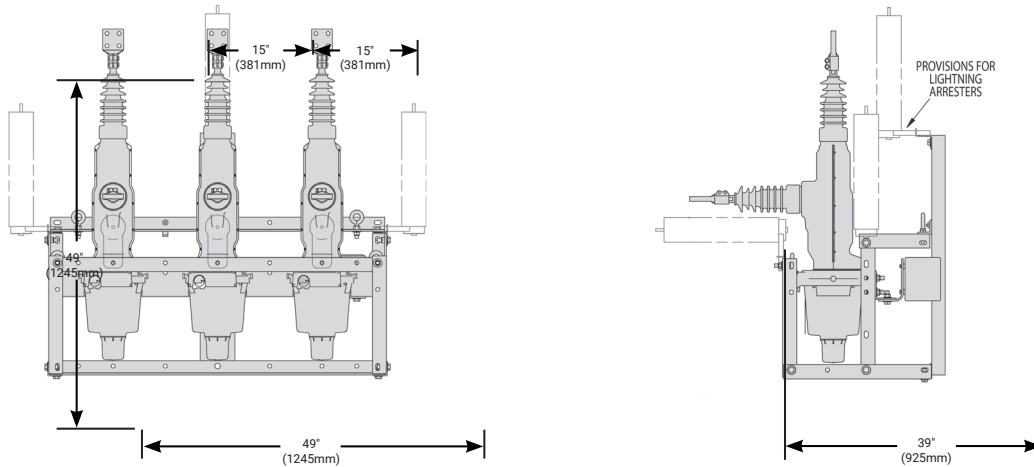

## Alley-Arm Frame (15kV shown)\*

- Outline is full site-ready package with two oil control power transformers
- Mounting bracket can be mounted on either side to match overhead lines
- Bracket position can be changed on-site without the need for special tools

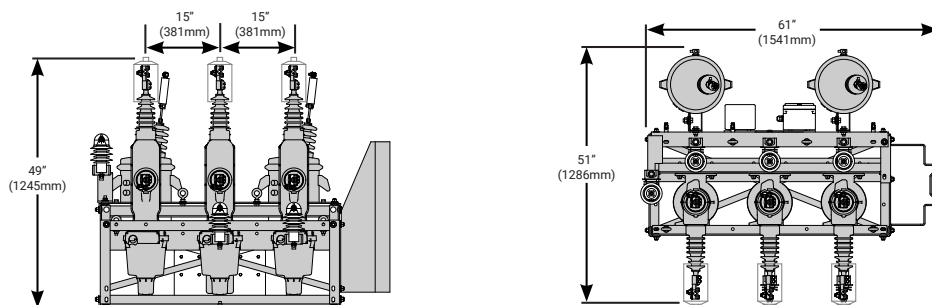

\*Dimensions are approximate. Do not use for construction. Brackets are aluminum as standard.



**Cross-Arm Frame (15kV shown)\***

- Phase B can be moved at site, without special tools, to either side of the pole to match the overhead line configuration
- Shown as a site-ready unit
- Galvanized steel frames are standard

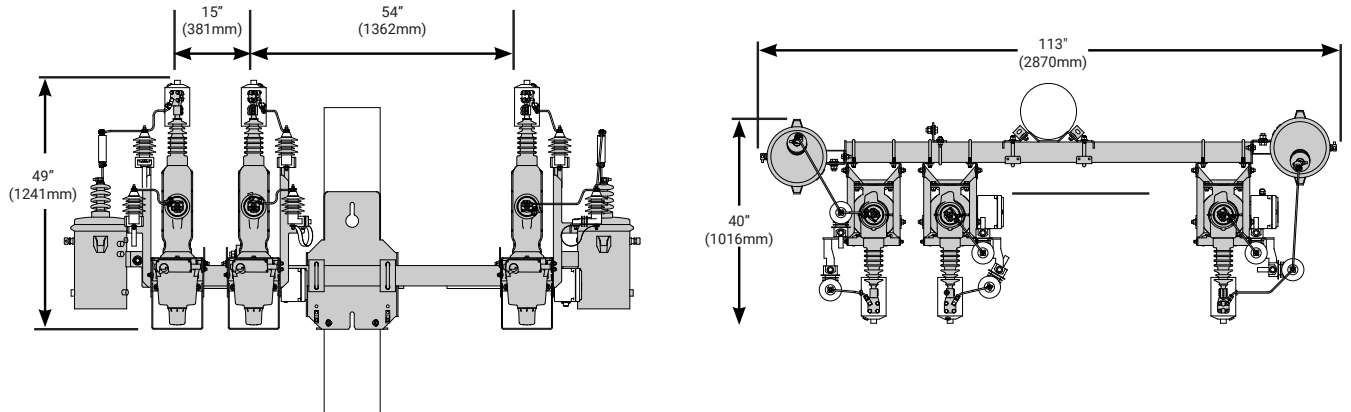

**Polemount Cluster Bracket (15kV shown)\***

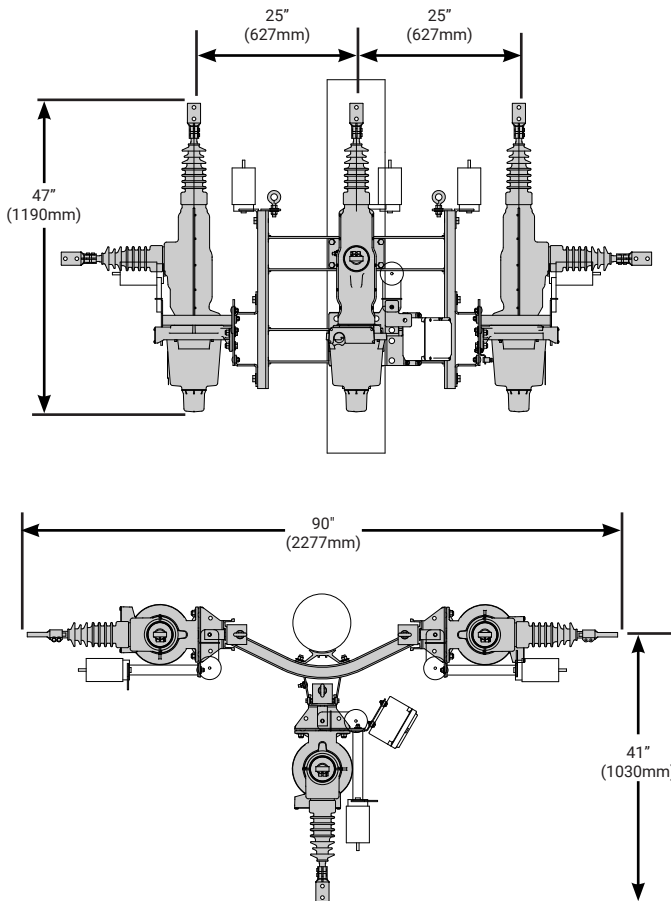

**Horizontal Insulator Bracket (38kV shown)\***

- Ideal for overhead applications where all three phase conductors are on the same side of the pole or for congested installations with minimal phase spacing
- Galvanized bracket is standard

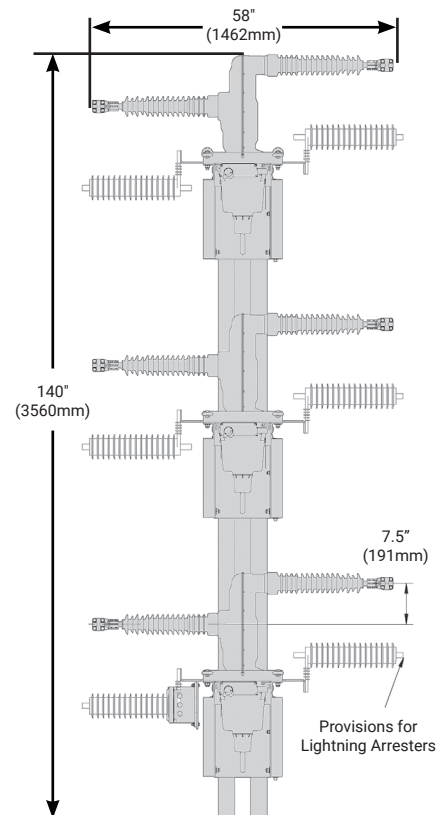

\*Dimensions are approximate. Do not use for construction.

## Riser Pole

---

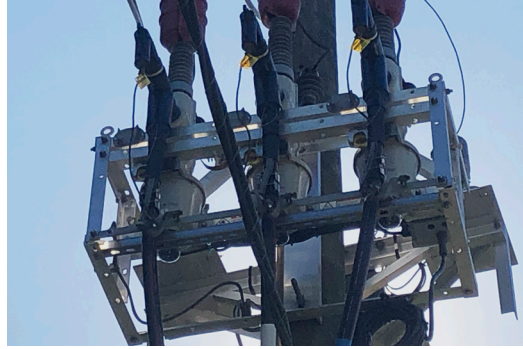

## Polemount Site-Ready Assembly (15kV shown)\*

---

- Pre-assembly of all auxiliary equipment significantly reduces installation time
- Includes oil potential transformers or solid dielectric voltage transformers, arresters, aerial lugs, terminal/junction boxes, wildlife protectors and all associated wiring
- Control cables are connectorized on both ends
- Various lengths are available for a cleaner installation
- Typically paired with SEL-651R2 control. Other controls available
- Galvanized steel frames are standard and stainless steel frames are an option



**Substation Mount Recloser\***

- Adjustable frame height
- Photo and drawings below show a three-phase mounted unit
- Substation frame is made of galvanized steel



Viper-ST with one set of external CTs. A second set of CTs can be provided on the other side.

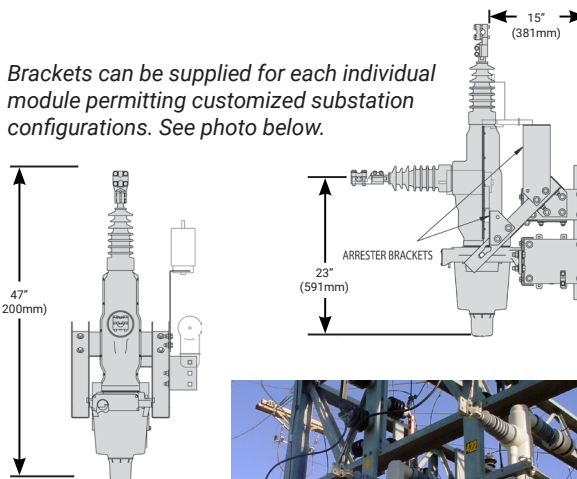
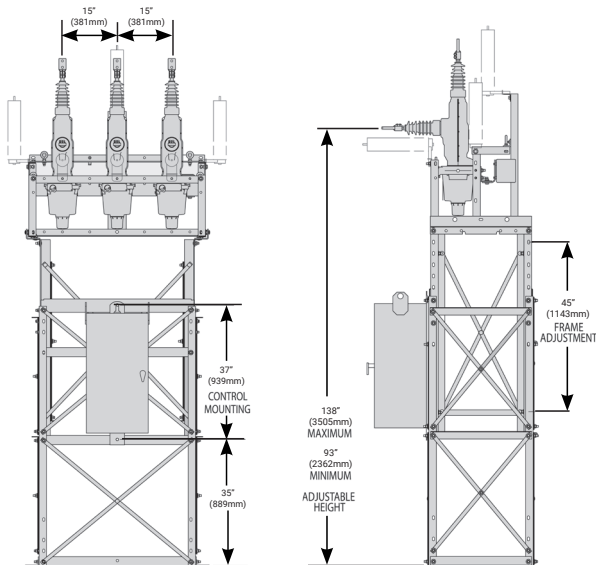

Brackets can be supplied for each individual module permitting customized substation configurations. See photo below.



Retrofit installation with "Z"-shaped module Viper-ST on individual frames.

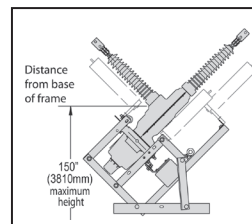

Drawing shows 45° angle mounting for applications requiring the same load and line side connector height.

**Viper-ST with Accusense (27kV shown)\***

- Centermount or cross-arm frames with factory-installed Accusense voltage sensors and lightning arresters
- Additional site-ready options are available, such as potential transformers for control power
- Aluminum frames are standard

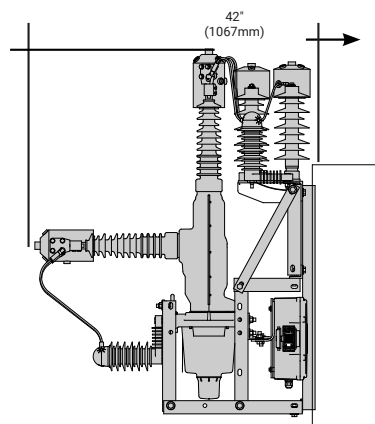
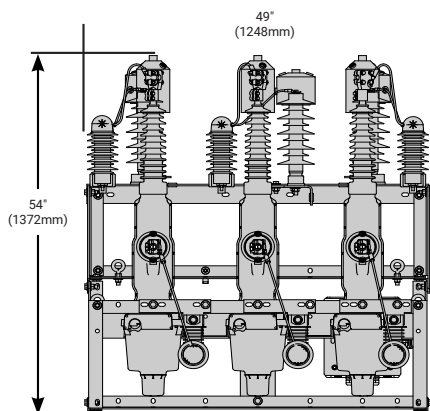

\*Dimensions are approximate. Do not use for construction.



## Padmount Applications

For applications where space is limited at the substation, fenceless substations, or where underground feeders require protection, Viper-ST solid dielectric reclosers can provide an ideal solution using a dead-front padmount design.

- Can be used as a breaker or as a tie-switch
- Cable connections can be provided with either a standard IEEE 600A apparatus or 200A deepwell interface for elbow connectors
- Controls can be mounted inside the recloser enclosure or within a separate adjacent low voltage enclosure
- Up to six internal LEA voltage sensors can be provided with "Z"-shaped (front/back access) or "C"-shaped (front only access) modules, perfect for tie points on FDIR schemes and automatic transfer applications
- Galvanized steel enclosure standard. Optional stainless steel enclosure

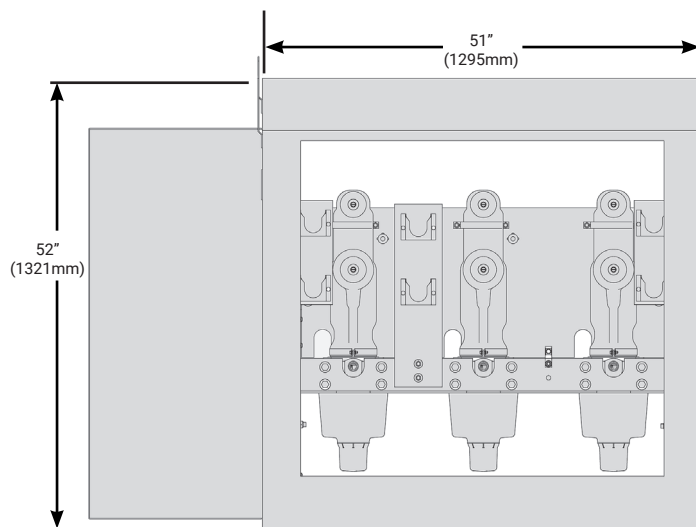

## Module Configurations

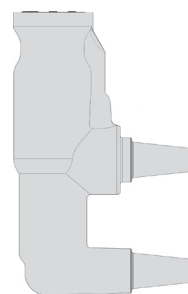

"C"-shaped Module

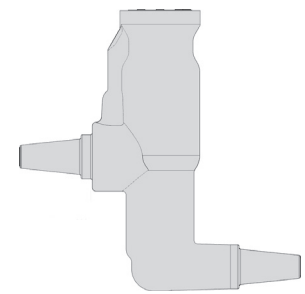

"Z"-shaped Module

\*Dimensions are approximate. Do not use for construction.

# Power Grid Automation Solutions

## Control Options



SEL-651R front access control for conventional recloser applications.



Beckwith M-7679 front access control for recloser applications.



ABB RER620 front access control for recloser applications.

Control Options	SEL-651R	Beckwith M-7679	ABB RER620
32-pin, 1/4 turn twist-lock connector	✓	✓	
42-pin Hasting Connector	✓	✓	✓

Consult your local G&W Electric Sales Agent for 14-pin control options.

## Lazer® Automation Solutions

G&W Electric LaZer power grid automation solutions deliver a wide array of pre-engineered systems, featuring custom programming, system testing, and upgradeable options to meet your specific application needs. These solutions offer scalable distributed or centralized architectures for monitoring and control, including FLISR, through a single point of contact. Whether integrating new or existing components—such as reclosers, switches, radios, SCADA systems, GIS imports, and controls—the transition from manual to semi-automated or fully automated operations is seamless. G&W Electric provides vendor-agnostic integration of relays and communication equipment.

Factory acceptance testing (FAT) ensures all systems are thoroughly configured and tested for reliability, reducing start-up time on-site and guaranteeing they meet application requirements under any conditions.

Our LaZer automation solutions team team works with you to develop solutions and designs optimized for your industry and application. We provide execution for various levels of automation by integrating switchgear, relays, communication equipment, and software to deliver a full turnkey solution.

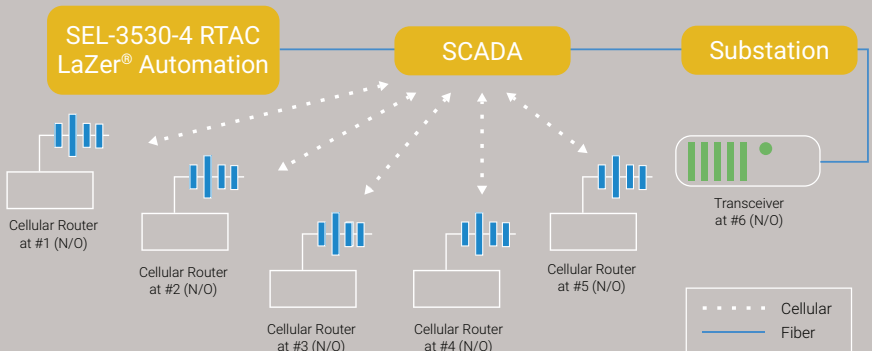

# Viper®-ST Typical Specifications

Electrical Ratings Chart for Viper®-ST						
Maximum Design Voltage, kV	15.5		27		38	
Impulse level (BIL), kV	110	110	125	125	170*	170
Continuous & load break current, A	800**	800**	800**	800**	800**	800**
8-hour Overload, A rms at 20°C**	960	960	960	960	960	960
60Hz Withstand, kV rms						
--- One minute (dry)	50	50	60	60	70	70
--- 10 second (wet)	45	45	50	50	60	60
Radio Influence Voltage, microvolts @ 100	9.4kV	9.4kV	16.4kV	16.4kV	23kV	23kV
Interrupting Current, kA rms sym.	12.5	16	12.5	16	12.5	20
Making Current, kA asym. rms	20	25	20	25	20	20
Making Current, kA asym. peak	32	42	32	42	32	32
Short Circuit Current, kA sym., 3 second	12.5	16	12.5	16	12.5	12.5
Mechanical endurance operations	10,000	10,000	10,000	10,000	10,000	10,000
Temperature range	-60°C to +65°C	-60°C to +65°C	-60°C to +65°C	-60°C to +65°C	-50°C to +65°C	-50°C to +65°C

\*38kV "C"-shaped module design rated to 150kV BIL  
 \*\*Optional Continuous Current up to 1000A (temperature up to +40°C) available

# Viper-ST Applications

Reclosers play a critical role in improving distribution reliability. By applying Viper-ST reclosers on the distribution system, permanent faults can be isolated to minimize outage areas and temporary faults can be cleared to restore power, thereby improving service continuity and system reliability.

The Viper-ST recloser can be used in a variety of applications including stand-alone reclosers, complex loop schemes with sectionalizing and tie switches, replacements for circuit breakers for feeder protection, and distributed generation intertie switches. The Viper-ST recloser is a versatile solution for your overcurrent protection and distribution automation needs.

High accuracy Accusense® voltage sensors integrated with the Viper-ST can be used as a tool to assist in improving power optimization initiatives such as volt-var optimization (VVO), conservation voltage reduction (CVR), and end-of-line metering. The Viper-ST solution with Accusense voltage sensors can serve as a metering point to provide data required for power factor adjustments, reducing voltages, optimizing voltages, and managing peak loads. External CTs can be installed over the Viper-ST insulators for applications requiring high accuracy current measurement.

## Stand-Alone Recloser Application

### Temporary Fault Between Viper and Load

G&W Electric provides a consultative approach to your recloser design. Our engineers provide a design that meets your specific needs whether you need customized cabinets, space saving frame configurations, or category 4 hurricane proof designs.

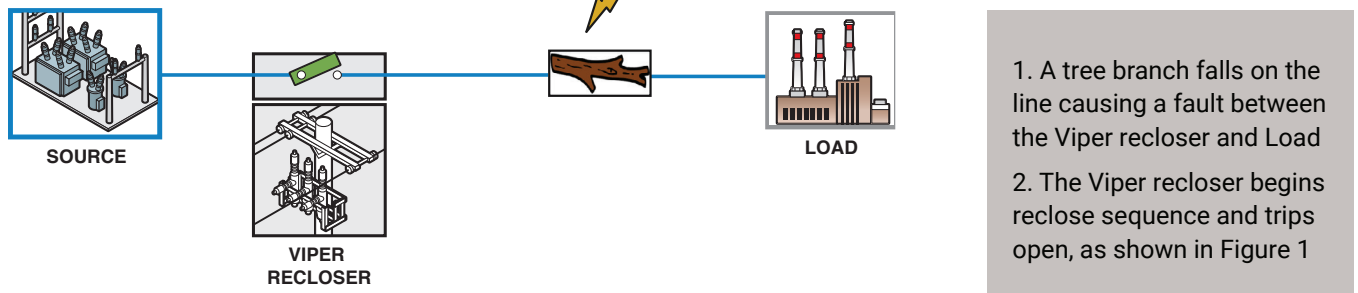

Figure 1: Stand-Alone Viper Recloser trips on a fault

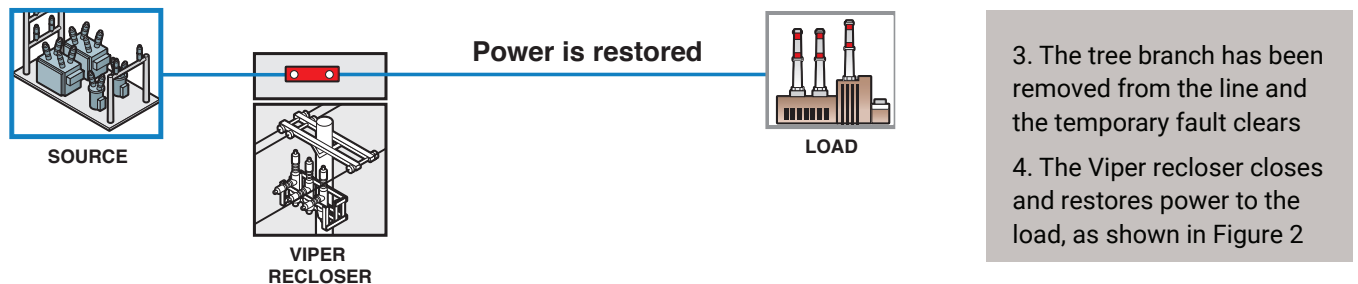
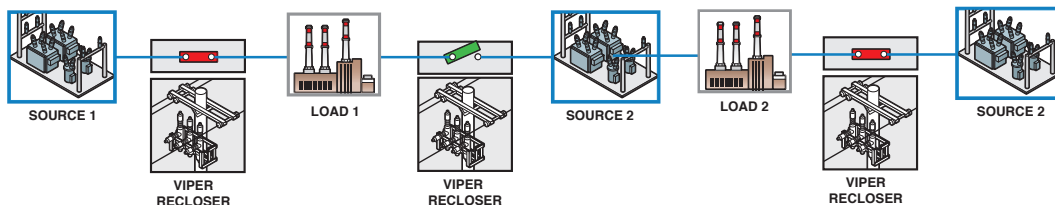

Figure 2: Stand-Alone Viper Recloser restores power after temporary fault cleared

## Main-Tie-Main Application

Any fault or loss of source can be handled by closing the open tie point to supply power to the loads.





## Automatic Transfer

For critical load applications such as hospitals, processing plants, military bases and others, automatic transfer schemes are common. For overhead systems, this scheme requires two switches, voltage sensors and current transformers, and a voltage-time controller. A loss of voltage on the primary source is sensed and initiates the control to open the primary source and close the alternate source switch to automatically restore power.

### Automatic Source Transfer Application – Single Line Example

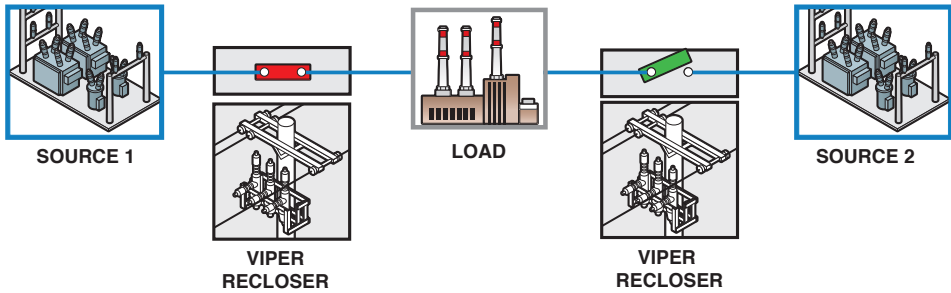

Source 1 is providing power to the load with Source 1 Viper recloser closed and Source 2 Viper recloser open.

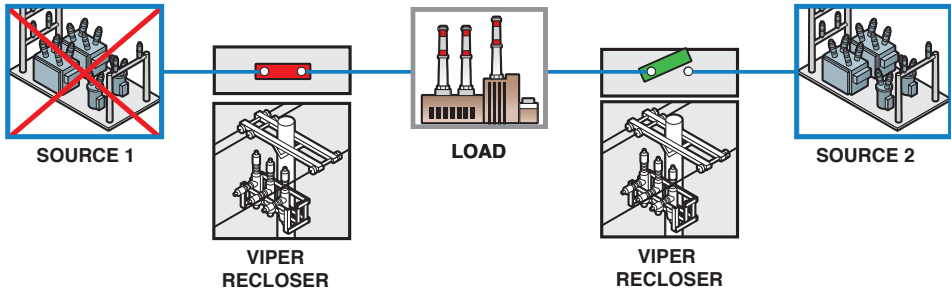

Source 1 fails. System recognizes loss of voltage.

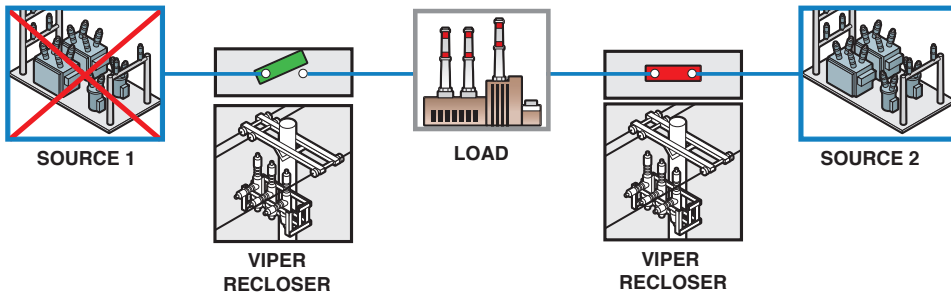

Source 1 Viper recloser opens upon loss of voltage and Source 2 Viper recloser closes to provide power to the load from Source 2.

For additional automation information, refer to our LaZer® Power Grid Automation brochure on our website.

# Proven Solutions for Every Industry

**G&W Electric is a global leader in power grid distribution and transmission. Our expansive suite of innovative products includes:**

- Padmount Switches
- Submersible Underground Vault Switches
- Vault and Padmounted Gas and Solid Dielectric Switchgear
- High Voltage and Medium Voltage Reclosers
- Sectionalizer and Load Break Switches
- Current Limiting System Protection for MV and LV Applications
- Sensors for Advanced Applications in System Efficiency (CVR and Volt/VAR) and Power Quality
- Power Grid Automation Solutions
- Distribution and Transmission Cable Accessories

**G&W Electric engineers flexible solutions for applications in the utility, industrial and commercial sectors.**

- Renewables
  - Solar
  - Wind
  - Hydro
- Hospitals
- Military/Government
- Oil & Gas
- Universities/Schools
- Commercial Buildings
- Utilities/Coops/Municipalities

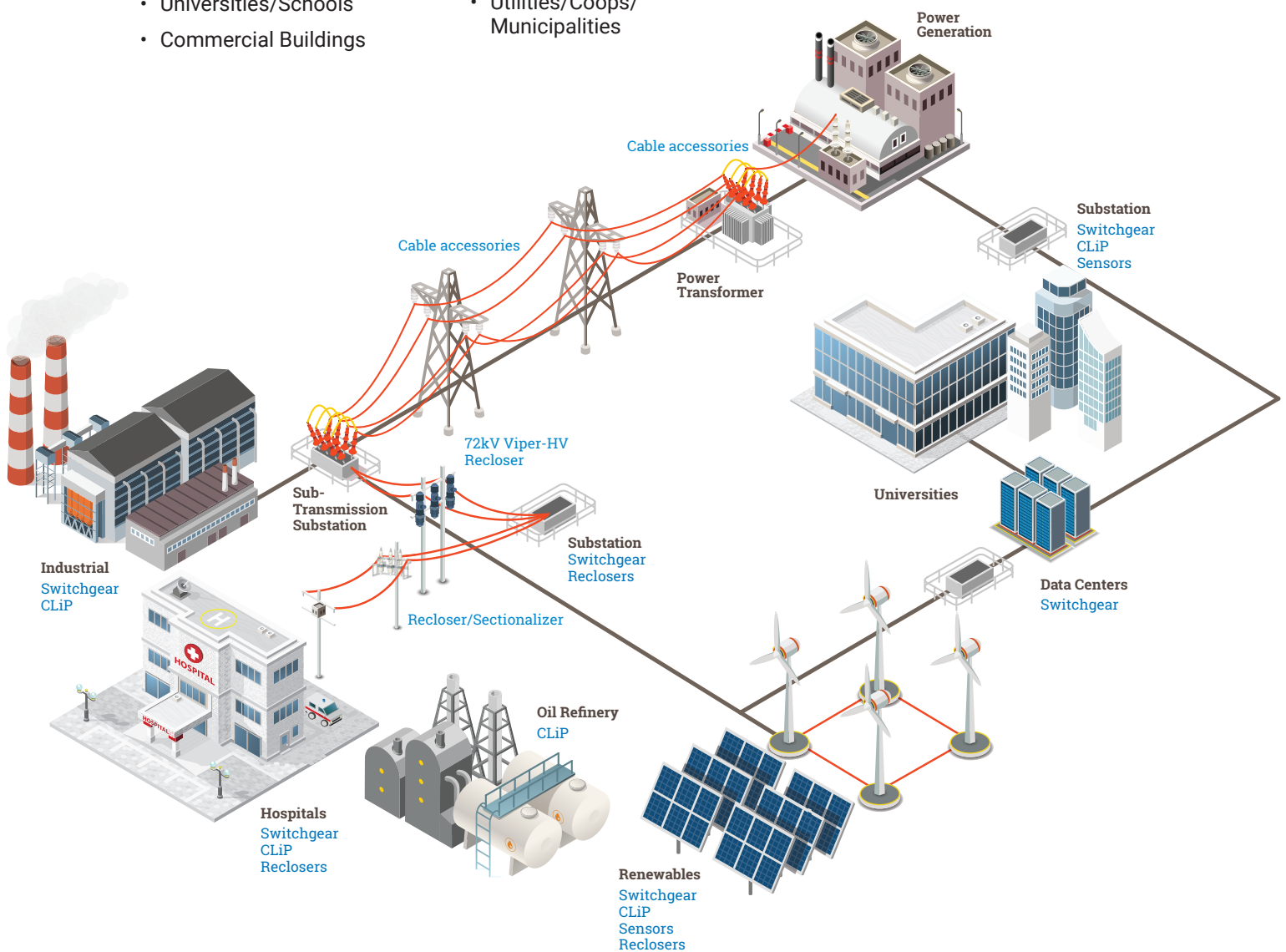



Contact us today

1+708.388.5010 or [info@gwelectric.com](mailto:info@gwelectric.com)

**G&W Electric**

Engineered to order. Built to last.

Since 1905, G&W Electric has been a leading provider of innovative power grid solutions including the latest in load and fault interrupting switches; reclosers; sensors; system protection equipment; power grid automation; transmission and distribution cable terminations; and joints and other cable accessories. G&W Electric is headquartered in Bolingbrook, Illinois, U.S.A., with manufacturing facilities and sales support in more than 100 countries, including Canada, Italy, China, Mexico, Brazil, India and Singapore. We help our customers meet their challenges and gain a competitive edge through a suite of advanced products and technical services.

[gwelectric.com](http://gwelectric.com)

© G&W Electric  
GW65-2024 12/24